

Transducer

Optoelectronic liquid level limit Transducer

Product group **720**

Type **06XX**

Sheet: 1/2

Revision: 3

Date:

7/03

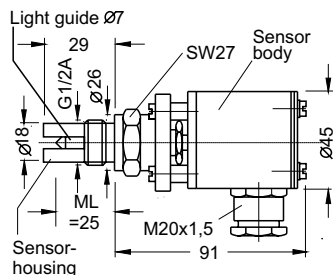

- Type 720.0660:
- 25 mm measuring length
 - Level detection
 - Guard fingers for Sensor tip
 - -65...+250 °C
 - 0...250 bar

measures in mm

Field of application

This Optoelectronic limit sensor is for signalling liquid level and interface limits. A big advantage is that to a great extent the optoelectronic sensor works independently of physical properties like density, dielectric constant, conductivity or color. The compact construction only needs a minimum of space and enables it to measure in very small volumes. Overfill prev. dev. (german WHG§19).

General Data

Accuracy:	±0,5 mm
Reproducibility:	±0,1 mm
Smallest R.I.-difference for Interface measurement:	0,02 R.I.
Light source:	IR-Light 930 nm
Ambient light:	max. 100 Lux
Orientation:	any
Connection:	G1/2A, DIN 910
Conical nipple:	DIN 7603
Weight, Type 720.06X0:	0,77 kg + 9,3 g/cm ML
Weight, Type 720.06X9:	1,07 kg + 9,3 g/cm ML

Design Data

Operating temp. Type 720.06X0:	-65 to +250 °C
Operating temp. Type 720.06X9:	-269 to +400 °C
Ambient temperature:	-65 to +95 °C
Operating pressure:	0 -25 MPa (0 - 250 bar)
Op. pressure special design:	0 - 50 MPa (0 - 500 bar)
Material Sensor-housing:	1.4571, Hastelloy, ...
Material light guide:	Clad core glass, Quartz Sapphire (max. ML=60 mm)
Material packing:	Graphite
Material housing:	Stainless steel

Electrical Data

Cable gland:	M20x1,5
Screw terminals:	3 * 2,5 mm2
Ingress protection EN 60529:	IP 65

Preferred dimensions

ML [mm]	Ordering no.			
	Level Standard	Level Ex	Interface Standard	Interface Ex
25	256941	257808	256958	256974
50	257477	258368	257584	257816
60	257485	257709	257592	257824
80	257493	257717	257600	257832
90	257501	257725	257618	257840
100	257519	257733	257626	257857
120	257527	257741	257634	257865
150	257535	257758	257642	257873
200	257543	257766	257659	257881
300	257550	257774	257667	257899
600	257568	257782	257675	257907
800	257576	257790	257683	257915

Connection diagram

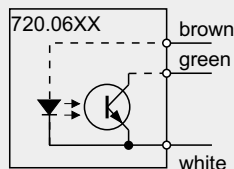

Certificates

Overfill prevention device in combination with Controller Type 720.0250, german WHG §19: DIBt Z-65.14-1

Subject to alterations

Ordering no.

7 2 0 . 1 1 X 3 0 0 X X X . 0 6 X X			
Applica-tion	Standard	1	
Measure	Level	1	
	Interface	2	
Measuring length	Measuring length in cm e. g. 150 mm = 015		X X X
	0	-65 ... +250 °C	T _{Proc}
	9	-269 ... +400 °C	
	6	without, ML=25 mm	Elongation
	8	with, ML=50-960 mm	

PHÖNIX

Messtechnik GmbH
Salzschlirfer Straße 13
D-60386 Frankfurt/M.
Tel. +49/69/41 67 42 -20
Fax +49/69/41 67 42 - 29
sales@phoenix-mt.com
www.phoenix-mt.com



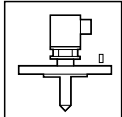

Transducer

Application hints

Product group **720**

Type **06XX**

Sheet: 2/2

Revision: 2

Date:

8/02

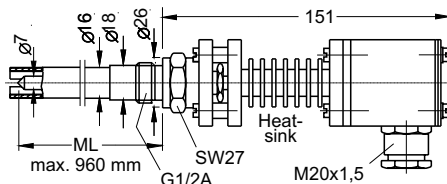

Type 720.0689
variable ML
Level detection
Guard fingers for
Sensor tip
-269...+400 °C
0...250 bar

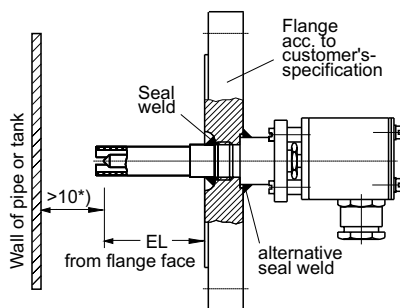

Type 720.0680
variable ML
Level detection
Flanged with
seal weld
Guard fingers for
Sensor tip
-65...+250 °C
0...250 bar
Material and type of
flange acc. to
customer's spec.

*) in case of polished surfaces >20

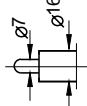

Interface detection
Sensor tip bar

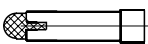

Design with
sieve Nr. 59390001
for diversion of gas
bubbles from
sensor tip

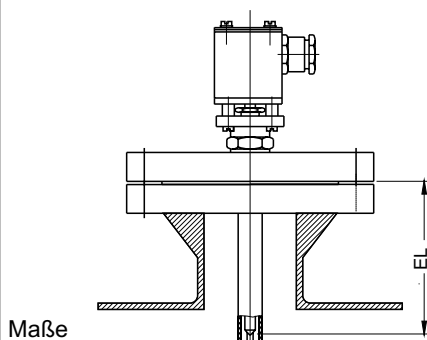

Maße
in mm

Installation top
mounted into
flange piece
e.g. as Overfill
prevention device

EL=Installation
length from
flange face
=ML - flange
thickness

Derating-Diagram

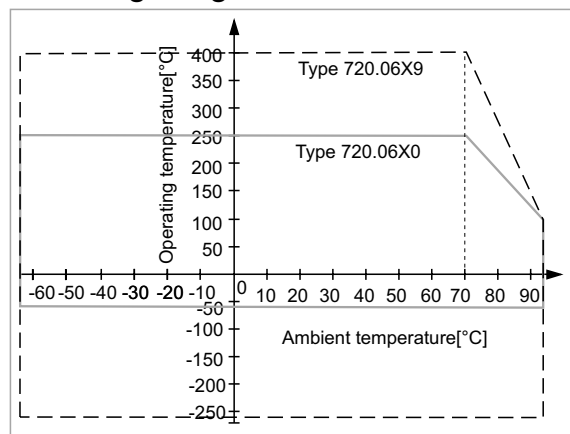

P-T-Diagram

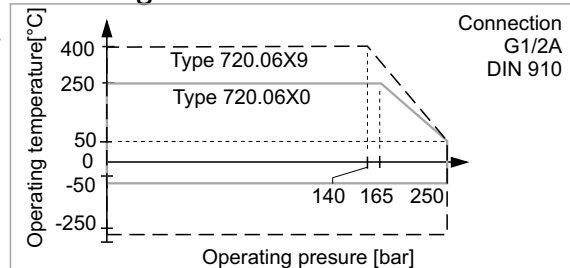

Flanges

DIN: from DN25 PN6, DL A/B/C/D/E, F/FA/N/NA
V13/R13/V14/R14, M/L
ANSI: from 1" ANSI 150, FF/RF/RJ(RTJ), LT/LG/ST/SG
LM/LF/SM/SF
Material: 1.4571, Hastelloy, Inconel
Incoloy, Monel, Titanium, Tantalum
Installation: Transducer screwed into flange or
seal welded with flange

Joint rings

D21 x 26 DIN 7603 for connection G1/2A
-10 to 400 °C: 1.1003 (soft iron)
-196 to 30 °C: 2.0090 (copper)

Subject to alterations

Ordering no. for Accessories

Flanges, material 1.4571, in parts

DN25 PN40 RF	5751432859B
DN25 PN40 groove	5751431759B
DN25 PN40 tongue	5751432959B
DN40 PN40 RF	5751631459B
DN40 PN40 groove	5751431959B
DN40 PN40 tongue	5751631859B
DN50 PN40 RF	5751631159B
DN50 PN40 groove	5751631759B

DN50 PN40 tongue	5751632459B
DN16 PN325 L	5751331659B
DN24 PN325 L	5751335559B
Seal weld	193798
Sensor protection	
sieve, material 1.4571	59390001
Joint rings	
Mat. 1.1003 D21x26 DIN 7603, sph.	D07603921026
Mat. 2.0090 D21x26 DIN 7603 Cu	D07603C26021

PHÖNIX

Messtechnik GmbH
Salzschlirfer Straße 13
D-60386 Frankfurt/M.
Tel. +49/69/41 67 42 -20
Fax +49/69/41 67 42 -29
sales@phoenix-mt.com
www.phoenix-mt.com

PHÖNIX