

SMART DIFFERENTIAL PRESSURE TRANSMITTER APRE-2000AL

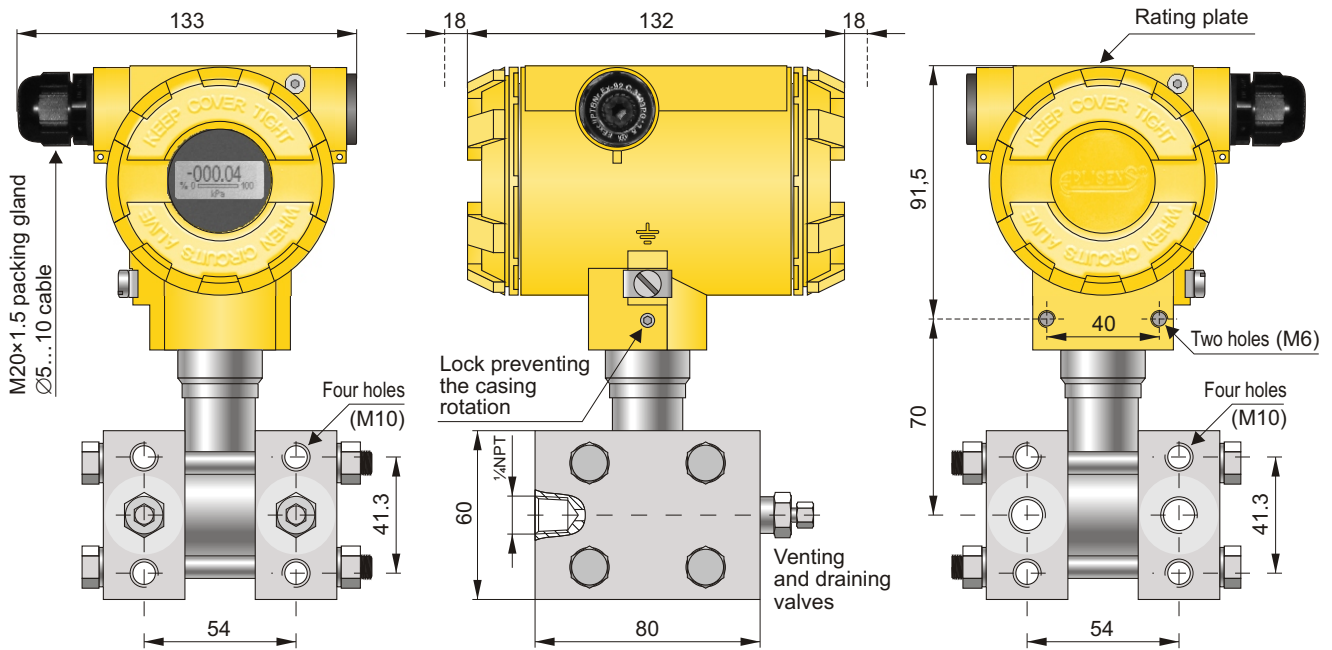

- ✓ Digital PROFIBUS PA signal
- ✓ 4...20 mA, 0...20 mA or 0...5 mA output signal + HART protocol
- ✓ ATEX Intrinsic safety
- ✓ PED Conformity (97/23/EC)
- ✓ Programmable zero shift, range and damping ratio
- ✓ Selectable linear or radical conversion characteristic
- ✓ Overloads up to 320 bar total static pressure
- ✓ Accuracy 0.075%



Transmitter **APRE-2000AL** – version with **type C** process connection to be mounted together with a valve manifold

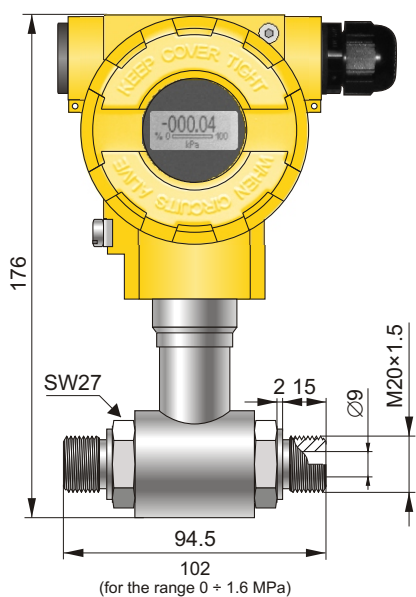

Transmitter **APRE-2000AL**
Version with **P type** process connection. Static pressure limit 40 bar

Application and construction

The APRE-2000AL transmitter is applicable to the measurement of differential pressure of gases, vapours and liquids. The active element is a piezoresistant silicon sensor separated from the medium by separating diaphragms and a specially selected type of manometric fluid. The special design of the active sensing element ensures that it is able to withstand pressure surges and overloads of up to 250 or 320 bar.

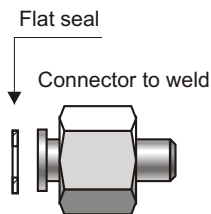

Example connection of impulse line

The casing is made of aluminium alloy cast, degree of protection IP65. The design of the casing enables the use of a local display, rotation of the display by 90°, rotation of the casing by 0–355° relative to the sensor, and a choice of cable direction.

The casing for the electronic parts is produced in three different versions:



Basic version APRE-2000AL

- ✓ 4...20mA output signal + HART protocol; or digital Profibus PA signal (description page 21)
- ✓ Possibilities of the adjusting both zero point and of the start and end of the measuring range according to set pressure with magnetised elements
- ✓ Possibility of locking the access to configuration changing with magnetised elements ATEX Intrinsic safety Ex II 1/2G EEx ia IIC T5/T6



Digital display version APRE-2000ALE

- ✓ 4...20mA, 0...20mA, 0...5mA output signal + HART protocol;
- ✓ Possibilities of the start and end of the measuring range according to set pressure with the display panel keys
- ✓ Configurable liquid crystal display (LCD) 3 1/2 digits (working temperature range -40...+85°C)
- ✓ No EEx or Profibus PA



Graphical display version APRE-2000ALW

- ✓ 4...20mA output signal + HART protocol; or digital Profibus PA signal (description page 21)
- ✓ Possibilities of the start and end of the measuring range according to set pressure with magnetised elements
- ✓ Possibility of locking the access to configuration changing with magnetised elements
- ✓ Configurable graphical display 5 digit with illumination (working temperature range -40...+85°C)
- ✓ ATEX Intrinsic safety Ex II 1/2G EEx ia IIC T5/T6

The working mode configuration enables the user:

- ♦ digital reading of the pressure acting on the sensing element;
- ♦ reading of the output current in % or in the user's units (taking into account the configuration, i.e. range, damping and conversion characteristic);
- ♦ rotation of displayed characters by 180°;
- ♦ positive or negative display.

Communication and configuration

The communication standard for data interchange with the transmitter is the HART protocol.

Communication with the transmitter is carried out with:

- a KAP-02 communicator,
- some other HART type communicators,
- a PC using an RS-HART converter and RAPORT-01 configuration software. Along with the RAPORT-01 is supplied the software SECTIONAL LINEARIZATION, which enables leading of the 21-point, non-linear user's characteristic into the transmitter.

The data interchange with the transmitter enables the users to:

- ♦ identify the transmitter;
- ♦ configure the output parameters:
 - measurement units and the values of the start points and end points at the measurement range;
 - damping time constant;
 - conversion characteristic (inversion, user's non-linear characteristic);
- ♦ read the currently measured pressure value of the output current and the percentage output control level;
- ♦ force an output current with a set value;
- ♦ calibrate the transmitter in relation to a model pressure.

Installation

The transmitter with **P** type process connection is not heavy, so it can be fitted directly onto impulse lines. For fitting in any desired position we recommend an universal Aplisens mounting bracket for 2" pipe (AL mounting bracket, see page 55).

The version with **C** type process connections can be fitted directly to a 3- or 5- valve manifold. We recommend factory-mounted transmitters with VM type valve manifold (page 55). A transmitter without a valve manifold can be fitted in any position on a 2" pipe or on a wall using the C-2" mounting bracket (page 55).

When the special process connections are required for the measurement of specific media levels in closed tanks (e.g. in the sugar and chemical industries) the transmitter is fitted with an Aplisens diaphragm seal. Sets of differential pressure transmitters with diaphragm seals are described in detail in the further part of the catalogue.

Electrical diagrams for transmitters with HART protocol

Version: **APRE-2000AL**
APRE-2000ALW

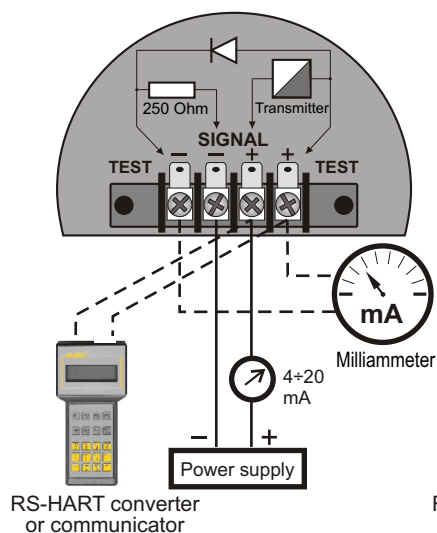

Version: **APRE-2000ALE**
with 4...20mA output signal

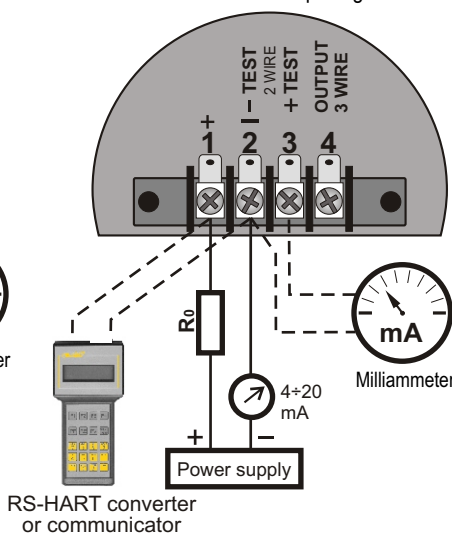

Version: **APRE-2000ALE**
with 0...5 or 0...20mA output signal

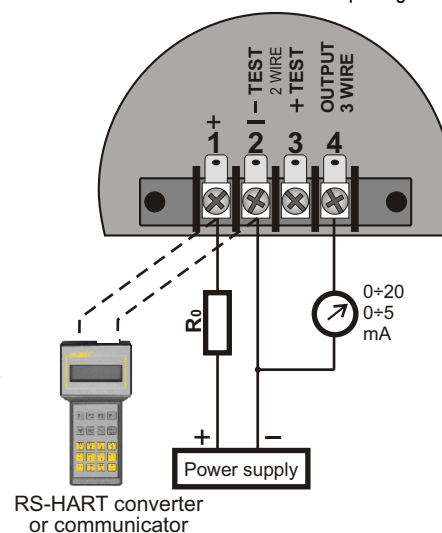

Measuring ranges

No.	Nominal measuring range (FSO)	Minimum set range	Rangeability	Overpressure limit / Static Pressure Limit
1	0...16 bar (0...1.6MPa)	1.6 bar (160 kPa)	10:1	250 bar / (320 bar option) (40 bar for P type process connection) (250 bar for PED version)
2	0...2 bar (0...200kPa)	0.2 bar (20kPa)	10:1	
3	0...1 bar (0...100kPa)	70 mbar (7kPa)	14:1	
4	0...0.25 bar (0...25kPa)	10 mbar (1kPa)	25:1	
5	-5...70 mbar (-0.5...7kPa)	4 mbar (0.4kPa)	18:1	
6	-0.5...0.5 bar (-50...50kPa)	0.1 bar (10kPa)	10:1	

Technical data

Metrological parameters

Accuracy	$\leq \pm 0.075\%$ of calibrated range
Long term stability (for the nominal measuring range)	\leq accuracy for 3 years
Thermal error	$< \pm 0.08\%$ (FSO) / 10°C max. $\pm 0.3\%$ (FSO) in the whole compensation temperature range
Thermal compensation range	$-25...80^\circ\text{C}$
Zero shift error for static pressure	0.01% (FSO) / 10 bar for range 4 0.03% (FSO) / 10 bar for range 5 0.08% (FSO) / 10 bar for ranges 1, 2, 3 and 6
Zeroing the transmitter in conditions of static pressure can eliminate this error.	
Time Constant	500 ms
Additional electronic damping	0...30 s
Error due to supply voltage changes	0.002% (FSO) / V

Electrical parameters

Power supply	10.5...36 V DC (EEx 12...28 V)
Additional voltage drop when display illumination switched on	3 V
Output signal	4...20 mA, two wire transmission APR-2000ALE: 4...20, 0...20 or 0...5 mA
Load resistance	$R[\Omega] \leq \frac{U_{\text{sup}}[\text{V}] - 10.5\text{V}^*}{0.02\text{A}} \cdot 0.85$
* – 13.5 V when display illumination switched on	
Resistance required for communication	250...1100 Ω

Materials

Wetted parts (type P) and (type C)	00H17N14M2 (316Lss)
Diaphragms	Hastelloy (C276)
Casing	Aluminium

Operating conditions

Operating temperature range (ambient temp.)	$-25...85^\circ\text{C}$ EEx version $-25...65^\circ\text{C}$
Medium temperature range	$-25...120^\circ\text{C}$ over 120°C – measurement with the use of impulse line or diaphragm seals up to 100°C PED version CAUTION: the medium must not be allowed to freeze in the impulse line or close to the process connection of the transmitter

Special versions, certificates

- ◇ **EEx** – Atex Intrinsic safety
- ◇ **PED** – European Pressure Equipment Directive N° 97/23/EC
- ◇ **-7...7 mbar** – basic range $-7...7$ mbar (overpressure limit and static pressure limit – 10 bar)
- ◇ **320 bar** – static pressure limit: 320 bar (not for PED version)
- ◇ **Tien** – transmitter designed for oxygen (only type P process connection; ranges: 3, 4)
- ◇ **Others**

Ordering procedure

APRE-2000AL /
APRE-2000ALE /
APRE-2000ALW /

Special versions: EEx, PED, -7...7mbar, 320bar, Tien, others – description	/	/	/	/	/
Nominal measuring range	/	/	/	/	/
Start of set range – in relation to 4 mA output	/	/	/	/	/
End of set range – in relation to 20 mA output	/	/	/	/	/
Process connection: type P, type C or type of diaphragm seal according to the diaphragm seals sheets	/	/	/	/	/

Accuracy depending on the set range

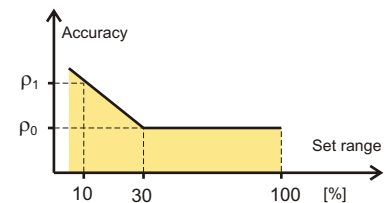

ρ_0 – error for nominal measuring range (0...100% FSO)

ρ_1 – error for range 0...10% FSO

$\rho_1 = 2 \times \rho_0$

Numerical error values are given in the technical data under metrological parameters

Example: APRE-2000ALE differential pressure transmitter / standard version / nominal measuring range $0 \div 1$ bar / cal. range $0 \div 0.6$ bar / type C process connection

APRE-2000ALE / 0 ÷ 1 bar / 0 ÷ 0.6 bar / C

SMART DIFFERENTIAL PRESSURE TRANSMITTER APRE-2000AL/Profibus PA

Application and construction

The APRE-2000AL/Profibus Pa transmitter is applicable to the measurement of differential pressure of gases, vapours and liquids. The active element is a piezoresistant silicon sensor separated from the medium by separating diaphragms and a specially selected type of manometric fluid. The special design of the active sensing element gives the element the pressure or overload impact strength of up to 250 or 320 bar.

The transmitter electronic system performs the digital processing of measurement and generates the output signal with the communication module according to Profibus PA standard. The transmitter function performance bases on profile 3.0 of Profibus PA standard.

The casing is made of high-pressure casting of aluminium alloy, IP-65 rated. The casing design allows using a local liquid crystal graphical display, 90° turn of display, 0–355° turn of casing relative to the sensor, and the choice of direction at cable insertion.

The APRE-2000AL/Profibus Pa transmitter is produced with P-type or C-type process connections (see fig. page 18) or, optionally, with Aplisens diaphragm seal.

The measuring ranges, according to the table, page 20.

Communication

The communication with the transmitter is achieved in two ways:

- ◇ cyclic – the transmitter sends primary measured value (4 bytes IEEE754) and status containing the information on the current state of transmitter and measurement validity (1 byte);
- ◇ acyclic – this way of communication is used to device configuration and to read both primary measured value and the status.

Configuration

Full configuration of transmitter settings, adjustment of the display mode, transmitter zeroing and calibration in relation to pressure standards proceeds with the PDM (Process Device Manager) software, by Siemens. The EED program library, worked out by Aplisens for cooperation with this transmitter, is helpful in the configuration.

Other commercial configuration software (e.g. Commuwin by Endress and Hauser, DTM/FDT tools) make transmitter configuration possible in the range of basic commands.

Enclosed to APRE-2000AL/Profibus PA is GSD file comprising the description of the transmitter basic properties such as transmission rate, type and format of input data, list of additional functions. GSD file is necessary for the software serving as a device for network configuration and makes the correct connection the appliance to Profibus network possible. The universal file GSD, designed for standard pressure transmitters made according to profile at revision 3 Profibus standard, may also be applicable to APRE-2000AL/Profibus PA.

The pressure transmitter APRE-2000AL/Profibus PA does not have the hardware address switch. This address may be adjusted with accessible configuration software.

Measurements in the areas under explosion hazard

For pressure measurements in the areas under explosion hazard the Atex intrinsically safe transmitters (Ex) II 1/2G EEx and IIB/T5 are available.

Technical data

Metrological parameters, materials of wetted parts, diaphragms and casing, and operating conditions – see the description, page 20.

Electrical parameters

Power supply (from DP/PA coupler)	11 ÷ 28 V DC
	12.05 ÷ 28 V DC – when display illumination switched on
	15 V DC – EEx version
Current consumption	14 mA
Output parameters	
Output signal	Digital communication signal Profibus – PA (according to EN 50170)
PA function	slave
Physical layer	IEC61158-2
Transmission rate	31.25 kBit/s
Modulation	Manchester II

Ordering procedure

APRE-2000AL/Profibus PA / / / ÷ /

Special versions: **EEx**, **PED**, **250bar**, **320bar**, **T1en**, **others** – description

W – casing with a display

Nominal measuring range

Process connection: type **P**, type **C** or the type of diaphragm seal, code according to the diaphragm seal sheets

Example: APRE-2000AL transmitter/ Profibus PA/ nominal measuring range 0÷250mbar/ process connection: type C

APRE-2000AL/Profibus PA / 0 ÷ 250 mbar / C

Electrical diagrams

