

Smart level probe SG.Profibus PA

- ✓ **Digital PROFIBUS PA signal**
- ✓ **Accuracy 0.1%**
- ✓ **Integrated internal overvoltage protection circuit**

Application

The SG.Profibus PA-25 smart level probe is applicable to measure liquid levels in tanks, deep wells and in intermediate pumping stations, fermentation chambers, settling tanks etc.

Principles of operation, construction

The probe measures liquid levels, basing on a simple relationship between the height of the liquid column and the resulting hydrostatic pressure. The pressure measurement is carried out on the level of the separating diaphragm of the immersed probe and is related to atmospheric pressure through a capillary in the cable.

The active sensing element is a piezoresistant silicon sensor separated from the medium by an isolating diaphragm. The electronic amplifier, which works in combination with the sensor, and is meant to standardize the signal, is additionally equipped with an overvoltage protection circuit, which protects the probe from damage caused by induced interference from atmospheric discharges or from associated heavy current engineering appliances.

The transmitter electronic system performs the digital processing of measurement and generates the output signal with the communication module according to Profibus PA standard. The transmitter function performance bases on profile 3.0 of Profibus PA standard.

Communication

The communication with the transmitter is achieved in two ways:

- ◆ cyclic – the transmitter sends primary measured value (4 bytes IEEE754) and status containing the information on the current state of transmitter and measurement validity (1 byte).
- ◆ acyclic – this way of communication is used to device configuration and to read both primary measured value and the status.

Configuration

Full configuration of probe: zeroing and calibration in relation to pressure standards proceeds with the PDM (Process Device Manager) software, by Siemens. The EED program library, worked out by Aplisens for cooperation with this probe, is helpful in the configuration.

Other commercial configuration software (e.g. Commwin by Endress and Hauser, DTM/FDT tools) make probe configuration possible in the range of basic commands.

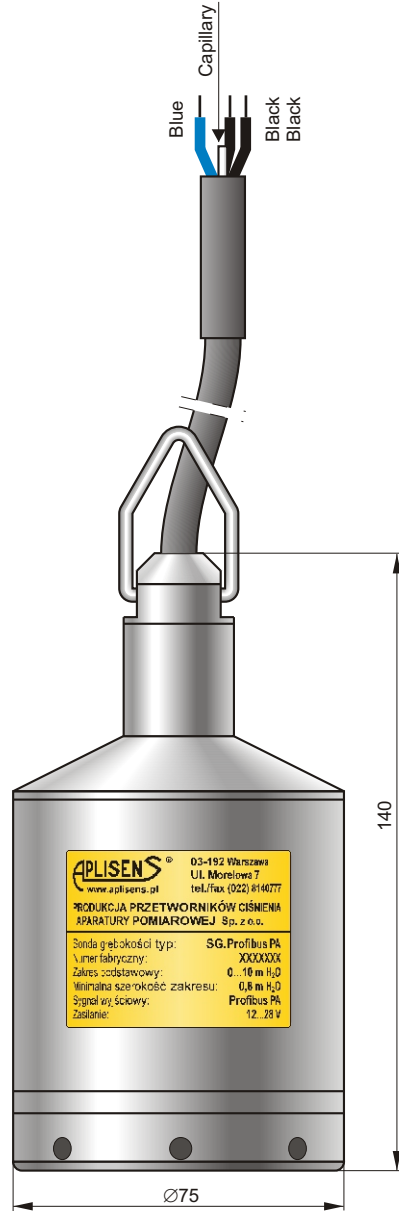

Enclosed to probe SG.Profibus PA is GSD file comprising the description of the probe basic properties such as transmission rate, type and format of input data, list of additional functions. GSD file is necessary for the software serving as a device for network configuration and makes the correct connection the appliance to Profibus network possible. The universal PA file GSD, designed for standard pressure transmitters made according to profile at revision 3 Profibus standard, may also be applicable to probe SG.Profibus PA.

The smart level probe SG.Profibus PA does not have the hardware address switch This address may be adjusted with accessible configuration software.

Installation, method of use

When lowered to the reference level, the probe may either hang freely on the cable hung under the steel lifting line or lie on the bottom of the tank. The probe is typically equipped with a 10 m long lifting line. The cable with the capillary can be extended using a standard signal cable. For the cable connection a special Aplisens **SG** cable hanger is recommended. The cable connection should be situated in a non-hermetically sealed box (the internal pressure inside the box should be equal to the atmospheric pressure), preventing water or other contaminants

from getting into the capillary. The Aplisens **PP** junction box is recommended. When the probe cable is being wound up, the minimum winding diameter should be 30cm and the cable should be protected from mechanical damage.

If there is a possibility of turbulence in the tank (for example, because of the mixer operating mixers or a turbulent inflow), the probe should be installed inside a screening tube (e.g. made of PVC). Cleaning the probe diaphragm by mechanical means is strictly prohibited.

Measuring ranges

No.	Nominal measuring range (FSO)	Maximum range (measurement limit)	Minimum set range	Overpressure limit (without hysteresis)
1	0...10 m H ₂ O	-1...11.5 m H ₂ O	0.8 m H ₂ O	100 m H ₂ O
2	0...100 m H ₂ O	-5...115 m H ₂ O	8 m H ₂ O	700 m H ₂ O

Technical data

Accuracy ≤ ±0.1% for nominal range
 ≤ ±0.3% for range 0...10% FSO

Long term stability ≤ 0.1% (FSO) for 2 years

Thermal error < ±0.08% (FSO) / 10°C
 max ±0.25% in the whole compensation temp. range

Thermal compensation range -25...80°C

Electrical parameters

Power supply (from DP/PA coupler) 10.5 ÷ 28 V DC

Current consumption 14 mA

Output parameters

Output signal digital communication signal Profibus – PA (according to EN 50170)

PA function slave

Physical layer IEC61158-2

Transmission rate 31.25 kBit/S

Modulation Manchester II

Operating conditions

Medium temperature range

-30...80°C for basic range 0...10 m H₂O
 -30...50°C for basic range 0...100 m H₂O

CAUTION: The medium must not be allowed to freeze in the immediate vicinity of the probe.

Degree of protection IP-68

Material of casing and diaphragm 00H17N14M2 (316Lss)

Cable shield POLYURETHANE

Special versions:

- ◇ **Teflon** – Teflon cable shielding
- ◇ **1.5 m H₂O** – Probe for nominal range 0...1.5 m H₂O (Accuracy 0.16%)

Ordering procedure

SG.Profibus PA / **/** **÷** **/ L = ... m / LS = ... m**

Special versions: Teflon

Nominal measuring range

Cable length

The length of steel line for LS > 10 m

PP junction box if required

Example: SG.Profibus PA probe, nominal measuring range 0 ÷ 10 m H₂O, cable 12 m, steel line 18 m

SG.Profibus PA / 0 ÷ 10 m H₂O / L = 12 m / LS = 18 m

Electrical diagram

